

TopClean 60

Professional standards of hygiene



TopClean 60 in detail



TopClean 60

Superb quality machine cleaning



Entry height (mm):
h 420
Dimensions (mm):
h 820-850, w 600, d 600

Health and safety issues are just as important to staff members as they are to patients. To ensure everyone in a healthcare setting enjoys maximum hygiene, leading infection control specialists recommend the regular use of standardised, machine-based cleaning and disinfection techniques.

The innovative *TopClean 60* multiwasher and disinfection machine offers the perfect way to fulfil hygiene requirements while simultaneously meeting work safety guidelines and leveraging maximum value from your investment.

Choose your preferred method of disinfection:

Thermal disinfection

A₀ value of 60 ensures outstandingly hygienic results – the best choice for most applications

Chemo-thermal disinfection

Specially designed for disinfecting heat-sensitive operating theatre boots with a dedicated disinfectant

Key benefits	Thermal disinfection	Chemo-thermal disinfection
Outstandingly hygienic results for heat-sensitive operating theatre boots with a dedicated disinfectant	–	•
Superbly hygienic results with an A ₀ value of 60 – the best method of disinfection for most applications	•	–
Rapid disinfection process gets washed items back in use quickly	•	•
Standardised cleaning processes ensure maximum safety and reliability	•	•
Machine cleaning keeps workplace free from contamination	•	•
Cost-effective cleaning and disinfection process with economical use of resources (electricity, water and process media)	•	•
Safe working environment thanks to automatic door locking and unlocking	•	•
Motivates and frees up staff so they have more time to spend on patients	•	•

Motivates and frees up staff so they have more time to spend on patients	•	•
--	---	---

Professional cleaning and disinfection

- Simple, user-friendly operation via clearly designed membrane keypad and display
- Choice of three programmes to meet different cleaning requirements:
 - Short cycle
 - Standard cycle
 - Intensive cycle
- Water can be changed in intensive cycle to tackle heavy soiling
- Safety through automatic door locking and unlocking
- Innovative *AktivPlus* fine filter technology boosts cleaning results
- Optimum entry height of 420 mm
 - Also suitable for transport containers and 10 litre buckets
- Working height can be adjusted by setting the appliance to a different height or using a range of plinths
- Can be easily integrated in a combined care unit
- Modular range of generously-sized cupboards ensures optimum use of storage space



SK 500 universal basket with rod option for optimum loading of soiled items (optional)



SK 500-1 basket for operating theatre boots (optional)



SKR 500-2 tray basket (optional)

Fully electronic control system with infrared technology

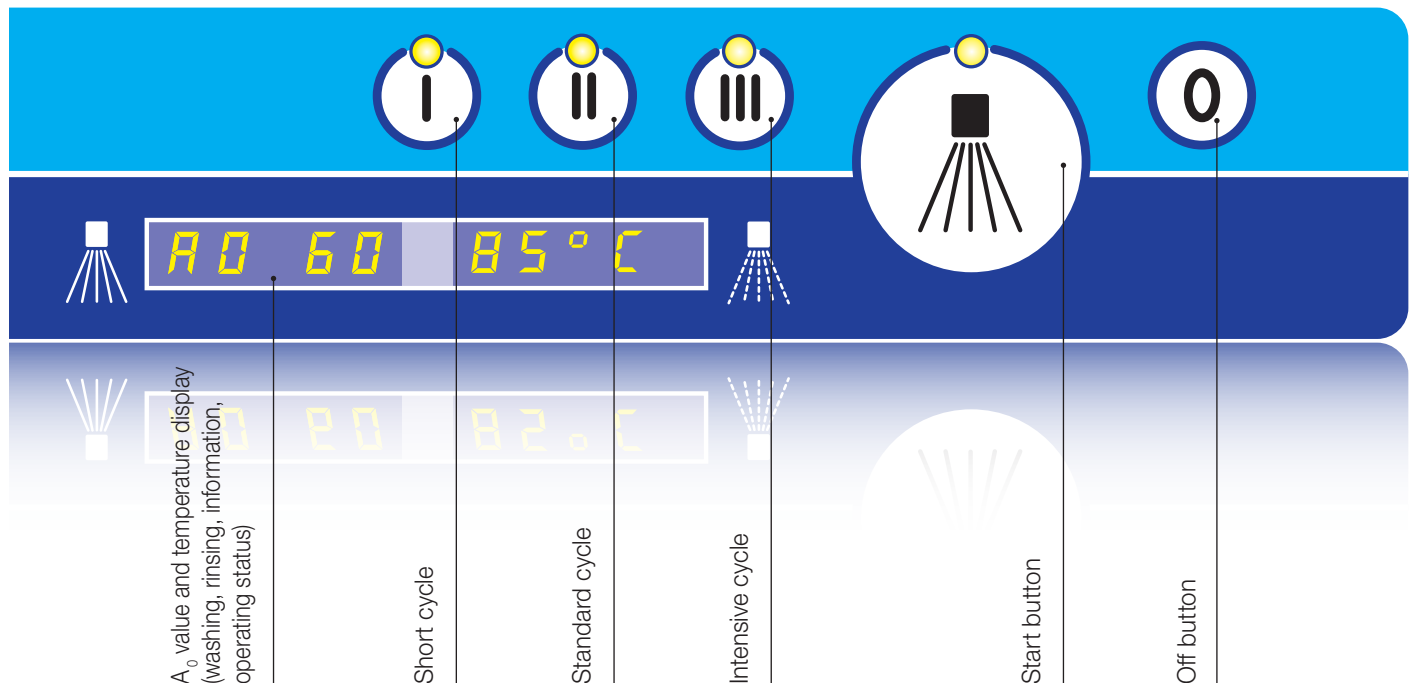

Advanced and user-friendly electronic control system

The MEIKO *TopClean 60* cleaning and disinfection machine comes with the advanced fully electronic *MIKE 2* control system as standard. Choose one of the three programmes by simply touching the relevant key. The digital display shows the progress of the wash cycle and alerts you to any important messages. With its clear icons and prominently displayed washing and rinsing temperatures, you will be impressed by how easy it is to operate and monitor the machine.

Cutting-edge MIKE 2 electronic control system with integrated infrared interface

MEIKO's intelligent *M-Commander W* software makes it easier than ever to read, define and modify data. You can even transfer the data to a PC and send it online to the factory or your customer service agent for immediate processing. That reduces the time, effort and costs involved in servicing and maintenance – offering another important benefit to customers.



Accessories

Reverse osmosis maximises water quality



Reverse osmosis system including safety assembly:

- Stop valve
- 10 µm fine filter with activated carbon

Benefits for you:

- First-class cleaning results
- Longer maintenance intervals
- Enhanced machine reliability and safety
- Savings on detergent and rinse aid

How reverse osmosis works

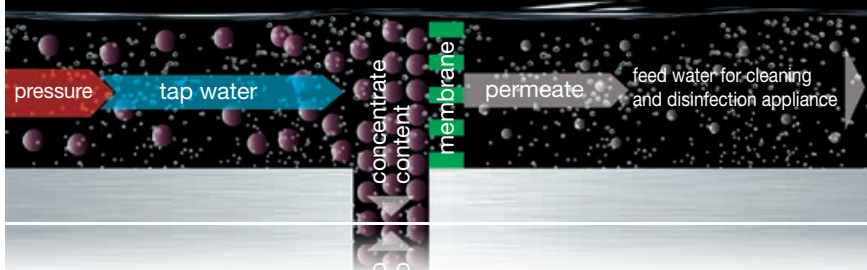

Specially developed for TopClean 60

- *RF 90* detergent (option): for cleaning of utensils
- *GT 500* rinsing agent (option): for optimum rinsing results and rapid drying of utensils



Example: Integrating TopClean 60 in a healthcare setting

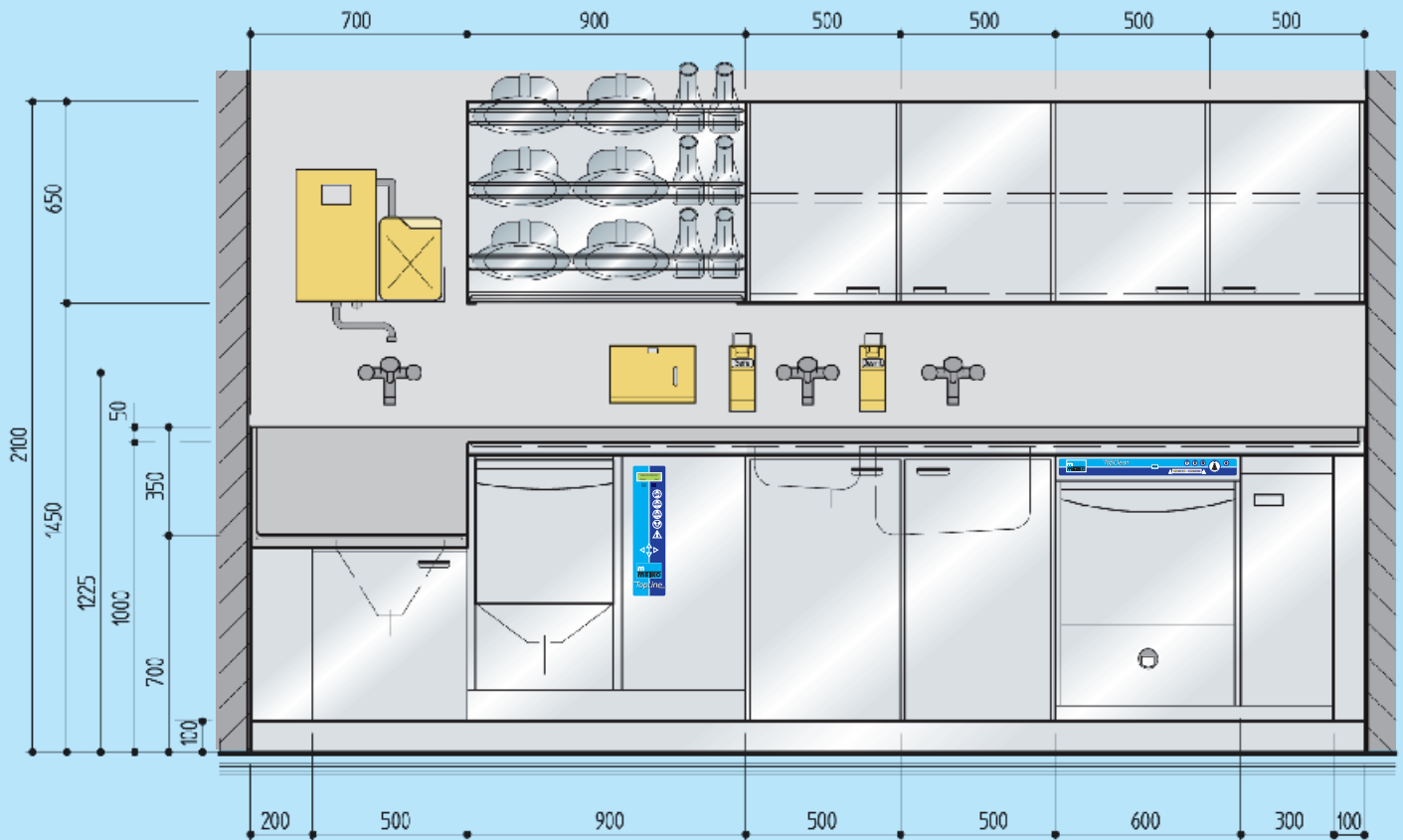

TopClean 60 with “AktivPlus”

MEIKO'S innovative *AktivPlus* wash water fine filter technology makes the wash

water cleaner than ever before. Thanks to ultra-efficient rinsing, only 2.6 litres

of water are required in each cycle to achieve superb cleaning results.

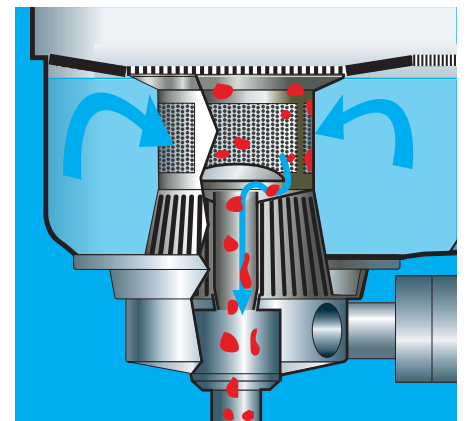
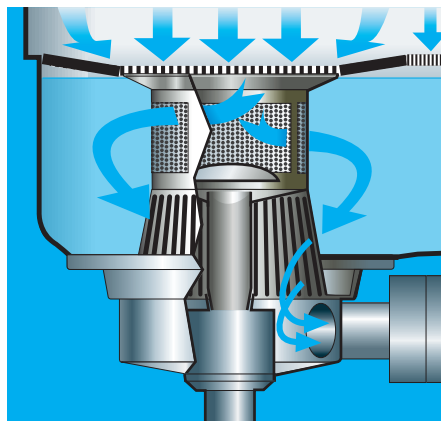

Technical data



The clean solution

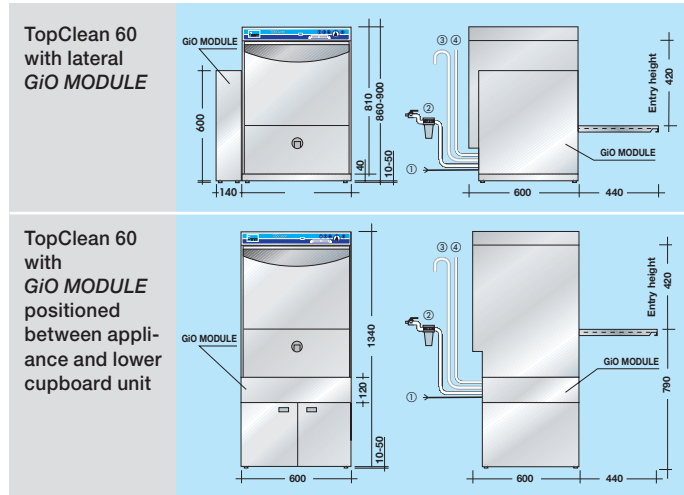

	TopClean 60	
Basket dimensions	mm	500 x 500
Entry height	mm	420
Pump motor	kW	0.55
Tank capacity	litres	11
Final rinse	litres	2.6
Tank heating	kW	4
Built-in water heater for feed water temperature of 10°C	kW	7.5
Total connected load for feed water temperature of 10°C	kW	12.2

Electrical installation:

Electrical connection: ① 3-phase NPE, 400 V, 50 Hz.
Circuitry meets the requirements of the Association of German Electrical Engineers (VDE).

Water installation with Aqua-Stop system:

The machines can be connected directly to the fresh water supply without the use of intermediate safety valves. Minimum flow pressure 0.6 bar, maximum pressure 5 bar. Installation standard EN 1717 must be observed. 3/4" drain outlet. Max. height of existing drain outlet on wall: 700 mm ③. Length of connecting pipes approx. 1.4 m from machine.

Water installation with GiO MODULE:

Cold water connection (max. 35°C), minimum flow pressure 1 bar, maximum pressure 5 bar. Conductivity of untreated water <1000 µS/cm. Total water hardness max. 28 °dH. Includes connection kit ②: Stop valve, pressure reducer, 10 µm filter with activated carbon, "HD" safety equipment (check valve and pipe vent) as per EN 1717. Feed line length approx. 3 m.

Appliance connection kit with armoured hose (without Aqua-Stop system). Concentrate drain 1/2" ④, length approx. 2 m. Permeate line and electrical cable between appliance and separate GiO MODULE approx. 3 m.

(1 bar = 100 kPa) (1 °dH approx. 0.18 mmol/l CaCO₃)

